

Growth Curve Analysis

Kevin J. Grimm
 Millmont Methodology Series
 October 21, 2005

Outline

- Overview
- Growth Modeling in SEM
- Example Data
- Extensions

Growth Curve Analysis

- Origins:
 - Rao (1958); Tucker (1958); Meredith & Tisak (1990); McArdle (1986), McArdle & Epstein (1987)
- Overviews:
 - McArdle & Nesselrode (2003), Singer & Willet (2003)

Growth Curve Analysis

- Latent Curve Analysis (LCA)
- Latent Growth Modeling (LGM)
- Hierarchical Linear Modeling (HLM)
- Multi level models of change (MLMC)
- Mixed effects model (MEM)
- Class of methods used to study change
 - explicit testing of hypotheses regarding the structure of longitudinal data

Growth Curve Analysis

- Requirements:
 - Interest in change
 - Theory of change
 - Longitudinal data (≥ 2 occasions)
- Does the construct change?
- How does the construct change?
- What effects how the construct changes?

$$Y[t]_n = 1 \cdot y_0 + A[t] \cdot y_1 + e[t]_n$$

$$y_{0n} = \mu_0 + \sigma_{0n}$$

$$y_{1n} = \mu_1 + \sigma_{1n}$$

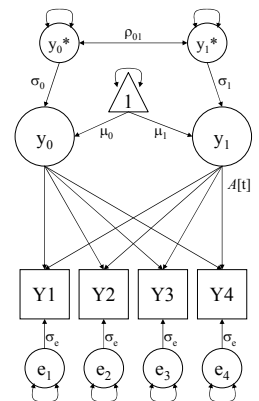
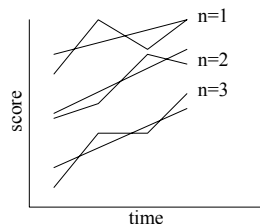

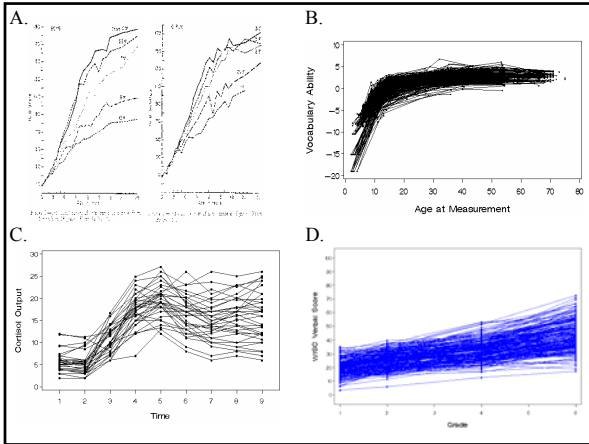

- ## Programs for GCA
- Mixed Effects/Multilevel Programs
 - SAS PROC MIXED/NLMIXED
 - SPSS MIXED
 - R (lme/nlme)
 - Stata
 - MLwin
 - HLM
 - Structural Modeling Programs
 - Mplus
 - AMOS
 - LISREL
 - Mx

- ## WISC Data
- Data = wis3raw.dat
 - 204 students assessed at 4 occasions
 - Grades 1, 2, 4, 6
 - 2 WISC scales + demographic variables
 - Verbal score, performance score
 - Component scores at grades 1 & 6
 - Mother's education, mother graduated HS
 - (constant = 1)
 - Variable names:
 - id
 - verb1 verb2 verb4 verb6 perfo1 perfo2 perfo4 perfo6
 - info1 comp1 simu1 vocal info6 comp6 simu6 voca6
 - momed grad constant

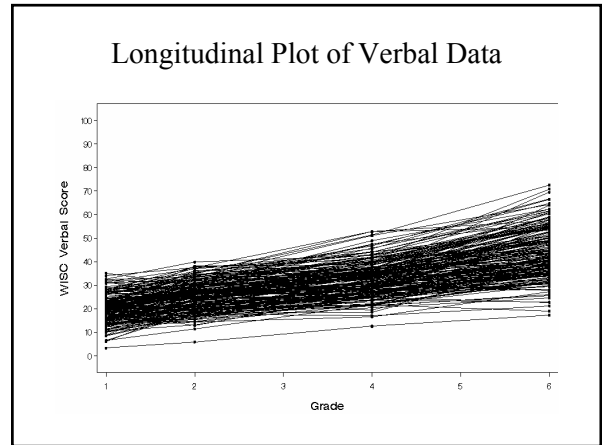

- ## Growth Curve Models
- Level Only

$$Y[t]_n = 1 \cdot y_0 + e[t]_n$$

$$y_{0n} = \mu_0 + \sigma_{0n}$$
 - Linear Growth (A[t]=0,1,3,5)

$$Y[t]_n = 1 \cdot y_0 + A[t] \cdot y_1 + e[t]_n$$

$$y_{0n} = \mu_0 + \sigma_{0n}$$

$$y_{1n} = \mu_1 + \sigma_{1n}$$
 - Latent Growth (A[t]=0, \alpha_1, \alpha_2, 5)

$$Y[t]_n = 1 \cdot y_0 + A[t] \cdot y_1 + e[t]_n$$

$$y_{0n} = \mu_0 + \sigma_{0n}$$

$$y_{1n} = \mu_1 + \sigma_{1n}$$

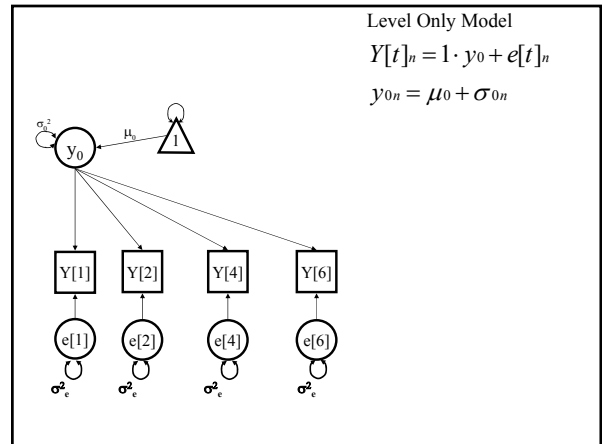

TITLE: Level Only Growth Model;
 DATA: FILE = wisc3raw.dat;
 VARIABLE:

Mplus Script

NAMES ARE
 id verb1 verb2 verb4 verb6 perfo1 perfo2 perfo4 perfo6 info1 comp1 simu1 voca1 info6 comp6 simu6
 voca6 momed grad constant;
 USEVARIABLES ARE verb1 verb2 verb4 verb6;
 ANALYSIS: TYPE = MEANSTRUCTURE MISSING H1;
 MODEL:
 !Level Factor Loadings
 level BY verb1@1;
 level BY verb2@1;
 level BY verb4@1;
 level BY verb6@1;
 !Means
 [verb1-verb6@0];
 [level];
 !Variances
 verb1 (resid); !constraining unique variances to equality
 verb2 (resid);
 verb4 (resid);
 verb6 (resid);
 level;
 OUTPUT: SAMPSTAT STANDARDIZED;

Mplus Output

Tests of Model Fit

Chi-Square Test of Model Fit
 Value 1382.267
 Degrees of Freedom 11
 P-Value 0.0000

Loglikelihood
 H0 Value -3170.968
 H1 Value -2479.835

Information Criteria
 Number of Free Parameters 3
 Akaike (AIC) 6347.936
 Bayesian (BIC) 6357.891
 Sample-Size Adjusted BIC 6348.386
 (n* = (n + 2) / 24)

RMSEA (Root Mean Square Error Of Approximation)

Estimate 0.782
 90 Percent C.I. 0.747 0.817
 Probability RMSEA <= .05 0.000

MODEL RESULTS

Mplus Output

LEVEL	BY	Estimates	S.E.	Est./S.E.
VERB1		1.000	0.000	0.000
VERB2		1.000	0.000	0.000
VERB4		1.000	0.000	0.000
VERB6		1.000	0.000	0.000
Means				
LEVEL		30.340	0.468	64.800
Intercepts				
VERB1		0.000	0.000	0.000
VERB2		0.000	0.000	0.000
VERB4		0.000	0.000	0.000
VERB6		0.000	0.000	0.000
Variances				
LEVEL		12.787	4.789	2.670
Residual Variances				
VERB1		127.728	7.302	17.493
VERB2		127.728	7.302	17.493
VERB4		127.728	7.302	17.493
VERB6		127.728	7.302	17.493

No Growth/Intercept Only Model

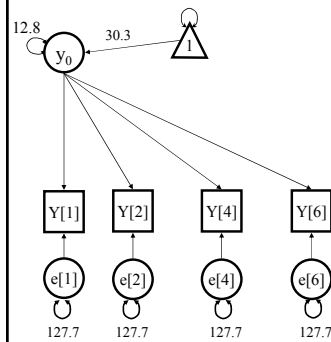

$$\mu_0 = 30.3$$

$$\sigma_0^2 = 12.8$$

$$\sigma_e^2 = 127.7$$

(A) Predicted Plot for Level Only Growth Model and
 (B) Longitudinal Residual Plot

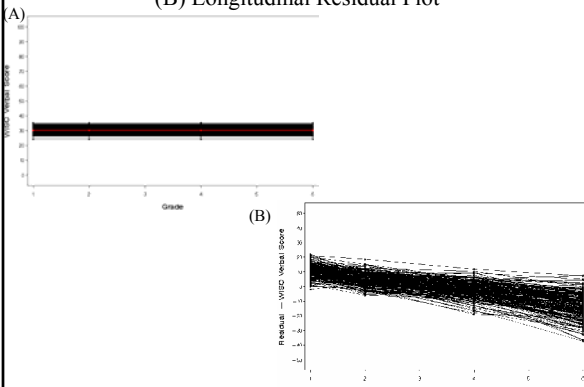
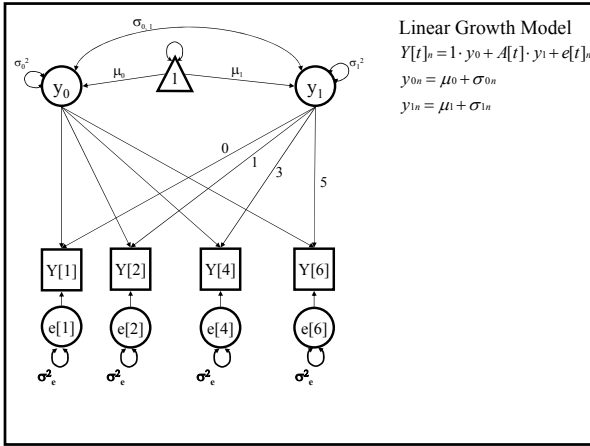

Table of Results

Parameter	Level	Linear	Latent
Fixed Effects			
Level Mean (μ_0)	30.3		
Slope Mean (μ_1)	--		
Basis Coefficients	--		
Random Effects			
Level Variance (σ_0^2)	12.8		
Slope Variance (σ_1^2)	--		
Level/Slope Covariance (σ_{01})	--		
Residual Variance (σ_e^2)	127.7		
Fit Statistics			
χ^2/df	1382/11		
$\Delta\chi^2/\Delta df$	--		
RMSEA (ϵ_p)	0.78		



Mplus Script

```

MODEL:
!Factor Loadings
level BY verb1@1;
level BY verb2@1;
level BY verb4@1;
level BY verb6@1;
!linear growth
slope BY verb1@0;
slope BY verb2@1;
slope BY verb4@3;
slope BY verb6@5;
!Means
[verb1-verb6@0];
[level slope];
!Variances
verb1 (1); !constraining unique variances to equality
verb2 (1);
verb4 (1);
verb6 (1);
!Factor Variances & Factor Covariance
level slope;
level WITH slope;

```

Mplus Output

TESTS OF MODEL FIT

Chi-Square Test of Model Fit		
Value	79.175	
Degrees of Freedom	8	
Loglikelihood		
H0 Value	-2519.422	
H1 Value	-2479.835	
Information Criteria		
Number of Free Parameters	6	
Akaike (AIC)	5050.844	
Bayesian (BIC)	5070.753	
Sample-Size Adjusted BIC	5051.743	
(n* = (n + 2) / 24)		
RMSEA (Root Mean Square Error Of Approximation)		
Estimate	0.209	
90 Percent C.I.	0.168	0.252
Probability RMSEA <= .05	0.000	

Mplus Output

MODEL RESULTS

	Estimates	S.E.	Est./S.E.
LEVEL BY			
VERB1	1.000	0.000	0.000
VERB2	1.000	0.000	0.000
VERB4	1.000	0.000	0.000
VERB6	1.000	0.000	0.000
SLOPE BY			
VERB1	0.000	0.000	0.000
VERB2	1.000	0.000	0.000
VERB4	3.000	0.000	0.000
VERB6	5.000	0.000	0.000
LEVEL WITH			
SLOPE	3.093	0.590	5.243
Means			
LEVEL	19.824	0.367	54.031
SLOPE	4.673	0.108	43.099
Variances			
LEVEL	19.853	2.771	7.165
SLOPE	1.529	0.245	6.236
Residual Variances			
VERB1	12.828	0.898	14.283
VERB2	12.828	0.898	14.283
VERB4	12.828	0.898	14.283
VERB6	12.828	0.898	14.283

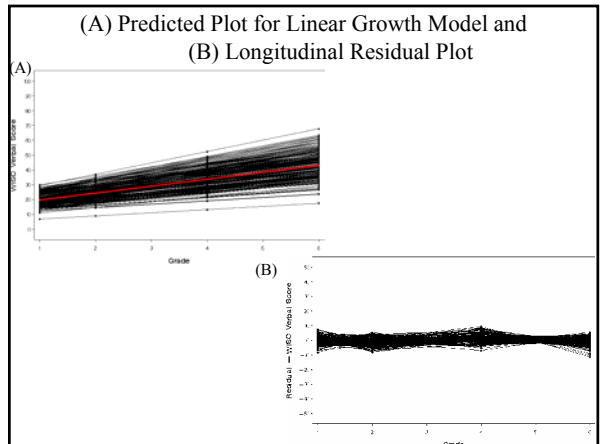
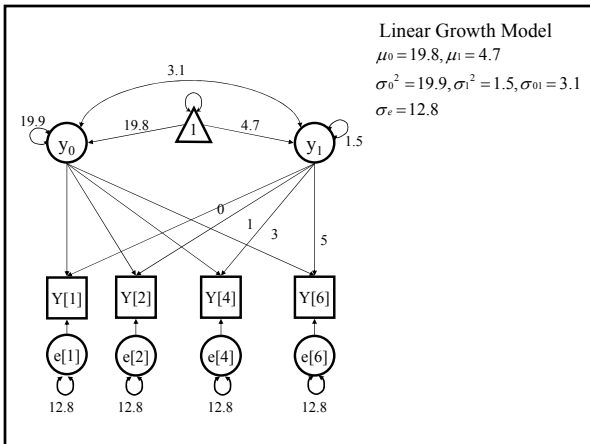
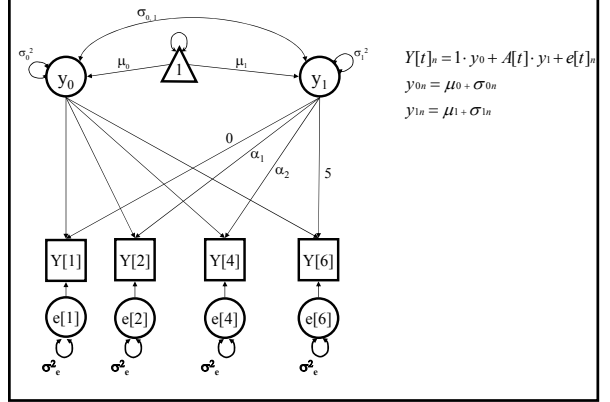

Table of Results

Parameter	Level	Linear	Latent
Fixed Effects			
Level Mean (μ_0)	30.3	19.8	
Slope Mean (μ_1)	--	4.7	
Basis Coefficients	--	=0,=1, =3,=5	
Random Effects			
Level Variance (σ_0^2)	12.8	19.9	
Slope Variance (σ_1^2)	--	1.5	
Level/Slope Covariance (σ_{01})	--	3.1	
Residual Variance (σ_e^2)	127.7	12.8	
Fit Statistics			
χ^2/df	1382/11	79/8	
$\Delta\chi^2/\Delta df$	--	1303/3	
RMSEA (ϵ_a)	0.78	0.21	

Latent Basis Growth Model



Mplus Script

```

MODEL:
!Factor Loadings
level BY verb1@1;
level BY verb2@1;
level BY verb4@1;
level BY verb6@1;
!latent basis growth
slope BY verb1@0;
slope BY verb2*;
slope BY verb4*;
slope BY verb6@5;
!Means
[verb1-verb6@0];
[level slope];
!Variances
verb1 (1); !constraining unique variances to equality
verb2 (1);
verb4 (1);
verb6 (1);
!Factor Variances and Factor Covariance
level slope;
level WITH slope;
    
```

Mplus Output

```

TESTS OF MODEL FIT

Chi-Square Test of Model Fit
Value                22.504
Degrees of Freedom   6
P-Value              0.0010

Loglikelihood
H0 Value            -2491.087
H1 Value            -2479.835

Information Criteria
Number of Free Parameters      8
Akaike (AIC)                   4998.174
Bayesian (BIC)                 5024.719
Sample-Size Adjusted BIC      4999.373
(n* = (n + 2) / 24)

RMSEA (Root Mean Square Error Of Approximation)

Estimate                0.116
90 Percent C.I.        0.068  0.169
Probability RMSEA <= .05  0.015
    
```

Mplus Output

```

MODEL RESULTS
Estimates    S.E.    Est./S.E.

LEVEL BY
  VERB1      1.000    0.000    0.000
  VERB2      1.000    0.000    0.000
  VERB4      1.000    0.000    0.000
  VERB6      1.000    0.000    0.000

SLOPE BY
  VERB1      0.000    0.000    0.000
  VERB2      1.168    0.060   19.516
  VERB4      2.637    0.057   46.074
  VERB6      5.000    0.000    0.000

SLOPE WITH
  LEVEL      2.801    0.611    4.587

Means
  LEVEL      19.713   0.393   50.102
  SLOPE      4.828    0.115   42.017

Variances
  LEVEL      20.830   2.758   7.554
  SLOPE      1.818    0.265   6.874

Residual Variances
  VERB1      11.005   0.771   14.283
  VERB2      11.005   0.771   14.283
  VERB4      11.005   0.771   14.283
  VERB6      11.005   0.771   14.283
    
```

Latent Basis Growth Model

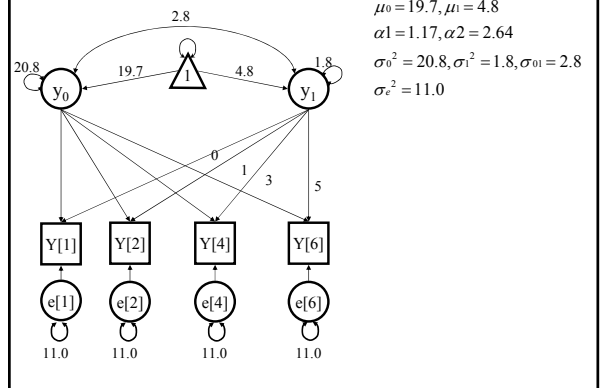

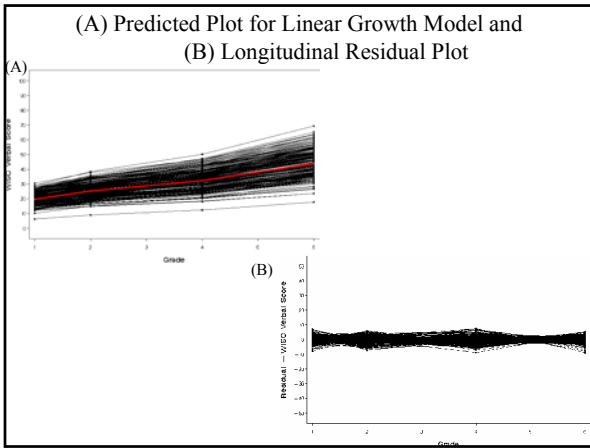
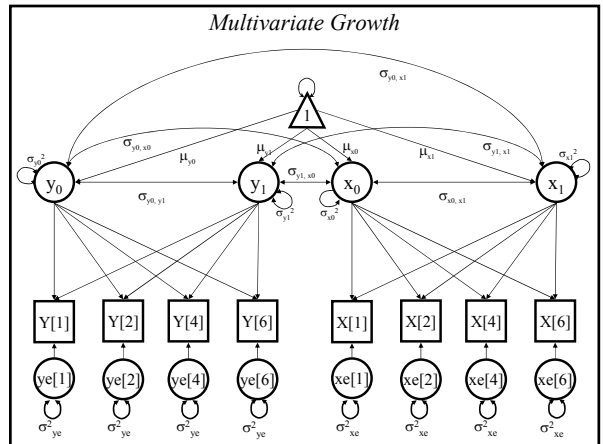
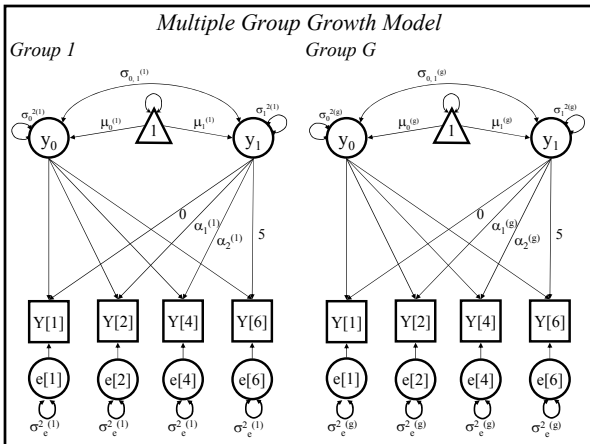
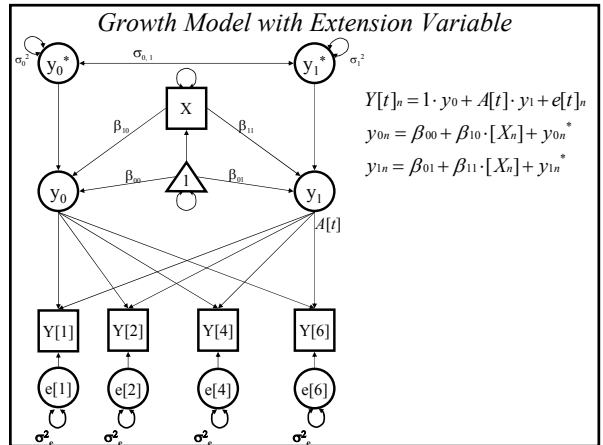
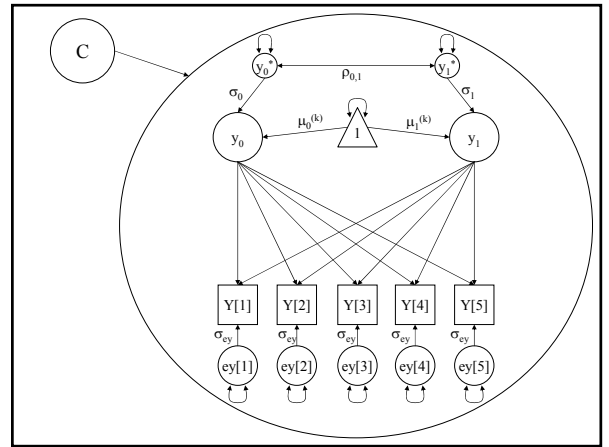
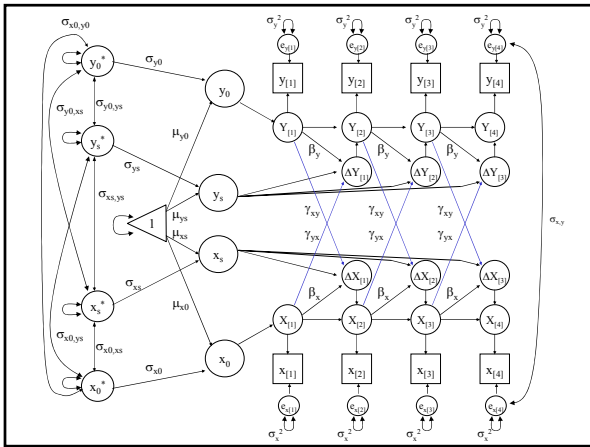
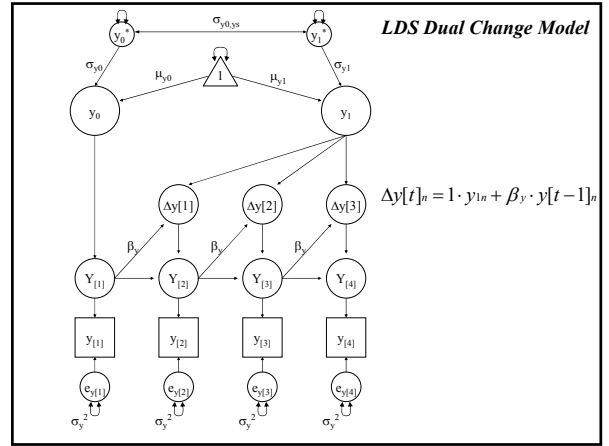
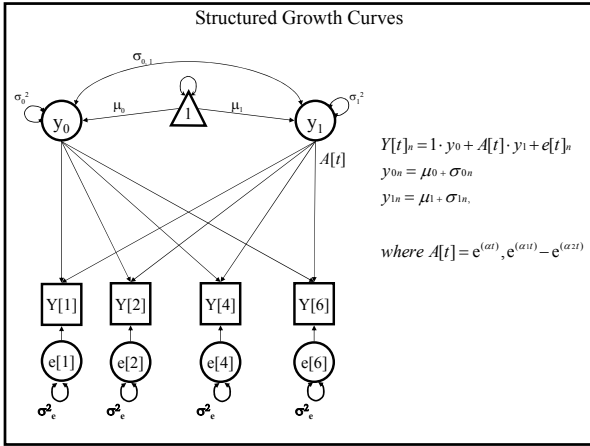

Table of Results

Parameter	Level	Linear	Latent
Fixed Effects			
Level Mean (μ_0)	30.3	19.8	19.7
Slope Mean (μ_1)	--	4.7	4.8
Basis Coefficients	--	=0,=1, =3,=5	=0, 1,17, 2.64, =5
Random Effects			
Level Variance (σ_0^2)	12.8	19.9	20.8
Slope Variance (σ_1^2)	--	1.5	1.8
Level/Slope Covariance (σ_{01})	--	3.1	2.8
Residual Variance (σ_e^2)	127.7	12.8	11.0
Fit Statistics			
χ^2/df	1382/11	79/8	23/6
$\Delta\chi^2/\Delta df$	--	1303/3	56/2
RMSEA (ϵ_p)	0.78	0.21	0.12

- Extensions*
- Growth Models with Extension Variables (McArdle & Epstein, 1987)
 - Multiple Group Growth Models (McArdle, 1989)
 - Multivariate Growth Models (McArdle, 1988)
 - Correlated Growth
 - Structured Nonlinear Growth Models (Browne & du Toit, 1991; Browne, 1993)
 - Basis follows a structured nonlinear equation (e.g. exponential)
 - Latent Difference Score Growth Models (McArdle, 2001; McArdle & Hamagami, 2001; Hamagami & McArdle, 2001)
 - Dynamic Growth
 - Growth Mixture Models (Muthén & Shedden, 1999; Muthén & Muthén, 2000)
 - Clustering based on developmental trends





References

Browne, M. W. (1993). Structured latent curve analysis. In C. M. Cuadras & C. R. Rao (Eds.), *Multivariate analysis: Future directions 2* (pp. 171-197). Amsterdam: Elsevier Science.

Browne, M. W. & du Toit, S. (1991). Models for learning data. In L. M. Collins & J. L. Horn (Eds.), *Best methods for the analysis of change: Recent advances, unanswered questions, future directions* (pp. 47-68). Washington, DC: American Psychological Association.

McArdle, J. J. (1986). Latent variable growth within behavior genetic models. *Behavior Genetics*, 16, 163-200.

Hamagami, F. & McArdle, J. J. (2001). Advanced studies of individual differences linear dynamic models for longitudinal data analysis. In G. A. Marcoulides & R. E. Schumacker, (Eds.), *New developments and techniques in structural equation modeling* (pp. 203-246). Mahwah, NJ: Erlbaum.

McArdle, J. J. (1988). Dynamic but structural equation modeling of repeated measures data. In J. R. Nesselroade & R. B. Cattell (Eds.), *Handbook of multivariate experimental psychology* (vol. 2, pp. 561-614). New York: Plenum.

McArdle, J. J. (1989). A structural modeling experiment with multiple growth functions. In R. Kanfer, P.L. Ackerman, & R. Cudeck (Eds.), *Abilities, motivation, and methodology: The Minnesota Symposium on Learning and Individual Differences* (pp. 71-117). Hillsdale, NJ: Erlbaum.

McArdle, J.J. (2001). A latent difference score approach to longitudinal dynamic structural analyses. In R. Cudeck, S. du Toit, & D. Sorbom (Eds.), *Structural equation modeling: Present and future* (p. 342-380). Lincolnwood, IL: Scientific Software International.

References

McArdle, J.J. & Epstein, D. (1987). Latent growth curves within developmental structural equation models. *Child Psychology*, 58, 110-133.

McArdle, J. J., & Hamagami, F. (2001). Latent difference score structural models for linear dynamic analyses with incomplete longitudinal data. In L. Collins & A. Sayer (Eds.), *New methods for the analysis of change* (pp. 139-175). Washington, DC: American Psychological Association.

McArdle, J.J. & Nesselroade J.R. (2003). Growth curve analysis in contemporary psychological research. In John A. Schinka & Wayne F. Velicer (Eds). *Handbook of psychology: Research methods in psychology* (Vol. 2, pp. 447-480). New York, NY: John Wiley & Sons.

Meredith, W. & Tisak, J. (1990). Latent curve analysis. *Psychometrika*, 55, 107-122.

Muthén, B. O. & Muthén, L. K. (2000). Integrating person-centered and variable-centered analysis: Growth mixture modeling with latent trajectory classes. *Alcoholism: Clinical and Experimental Research*, 24, 882 – 891.

Muthén, B. & Shedden, K. (1999). Finite mixture modeling with mixture outcomes using the EM algorithm. *Biometrics*, 55, 463-469.

Rao, C.R. (1958). Some statistical methods for the comparison of growth curves. *Biometrics*, 14, 1-17.

Singer, J. D & Willet, J. B. (2003). *Applied Longitudinal Data Analysis: Modeling Change and Event Occurrence*.

Tucker, L.R (1958). Determination of parameters of a functional relation by factor analysis. *Psychometrika*, 23, 19-23.